

OPTIMA™

Overcurrent Protection Module - Fuseholder

for **13/32" x 1 1/2"** (10mm x 38mm) Fuses

OPM-1038

Non-Switch Series



Physical Characteristics:

- Small size matches 45mm IEC starter width.
- Fits #8-18 AWG stranded wire, #10-18 AWG solid wire.
- 3-pole version.

Product Features:

- "Open" fuse indication lights. (Min. 100V required)
- Cam action handle for easy removal.
- Finger safe terminals. (Qualified as IP20 per IEC529)
- Removable module for convenient fuse loading.
- 35mm DIN-rail or screw panel mounting (#8 screw, 1 1/4" long).
- Dead front construction.

Catalog Symbol:

Series	Fuse Type	Communication								
<table border="1" style="display: inline-table; border-collapse: collapse;"> <tr> <td>O</td><td>P</td><td>M</td><td>-</td><td>1</td><td>0</td><td>3</td><td>8</td> </tr> </table>	O	P	M	-	1	0	3	8	<input type="checkbox"/>	<input type="checkbox"/>
O	P	M	-	1	0	3	8			
	Blank - 10 x 38mm or 13/32" x 1-1/2"	C - Communication Feature								
	R - Class CC									

Additional Features:

- Option for remote "open fuse" status indication feature available (less down-time).
- Offered with Class CC rejection clips or European 10mm x 38mm clips to meet global needs.
- Wire ready: Saves time as terminals are ready to accept wires.

Materials: Grey Thermoplastic

UL Flammability: UL 94V0

Agency Information:

UL - see table below

CSA Certified: C22.2 No. 39, Class 6225-01, File 47235

IEC - see table below

Shipping Weight: Approx. 213g (.47 lb.)

Carton Quantity: 1

Catalog Number	Electrical Rating	SC Rating	Clips	Remote Open Fuse Indication	UL Information			IEC
					Std.	File	Guide	
OPM-1038	30A, 600V UL/CSA** (Max. 3 Watts per fuse) 32A, 660V IEC	*	Non-rejection, 10 x 38mm or 13/32" x 1-1/2"	No	Recognized UL 512	E14853	IZLT2	IEC 269-2-1
OPM-1038R	30A, 600V UL/CSA**	200kA	Rejection, Class CC	No	Listed UL 512	E14853	IZLT	
OPM-1038C	30A, 600V UL/CSA** (Max. 3 Watts per fuse) 32A, 660V IEC	*	Non-rejection, 10 x 38mm or 13/32" x 1-1/2"	Yes	Recognized UL 512	E14853	IZLT2	IEC 269-2-1
OPM-1038RC	30A, 600V UL/CSA**	200kA	Rejection, Class CC	Yes	Listed UL 512	E14853	IZLT	

*Rating varies depending on fuse used in module.

**DC Voltage Rating: 600V UL/CSA

Recommended Fuse Types:

Class CC	Midget (non-rejection)
LP-CC	KTK
KTK-R	FNM
FNQ-R	FNQ

CE CE logo denotes compliance with European Union Low Voltage Directive (50-1000Vac, 75-1500Vdc). Refer to Data Sheet: 8002 or contact Bussmann Application Engineering at 636-527-1270 for more information. Applies to OPM-1038 and OPM-1038R.



OPTIMA™
 Overcurrent Protection Module - Fuseholder
 for **1 3/32" x 1 1/2"** (10mm x 38mm) Fuses

OPM-1038
 Non-Switch Series

Dimensional Data

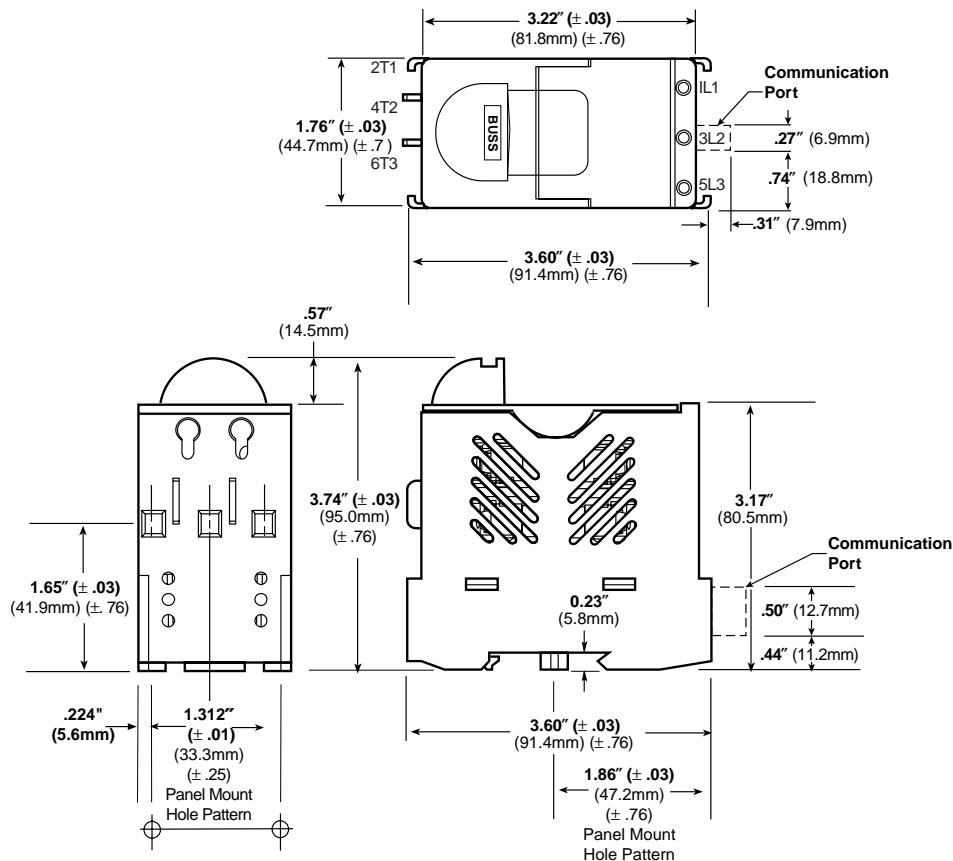

Spare Fuseholder: Part No. 5TPH

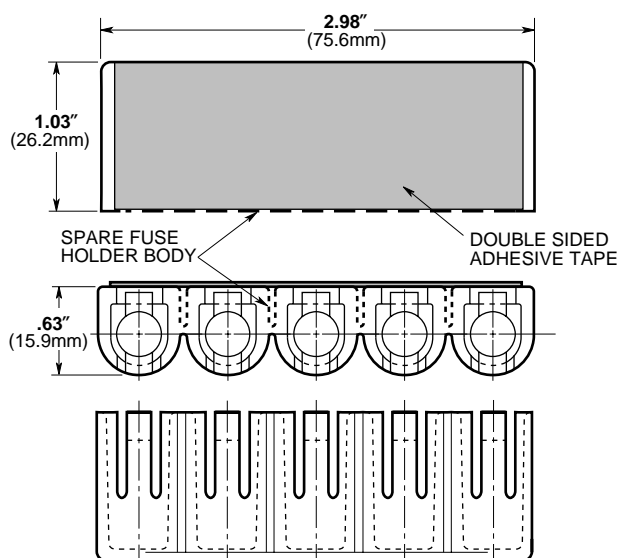

OPTIMA™ Overcurrent Protection Module - Fuseholder for 1³/₃₂" × 1¹/₂" (10mm × 38mm) Fuses

OPM-1038 Non-Switch Series

OPEN FUSE INDICATION

Status Output Specifications:

- *Minimum operating voltage: 460Vac, 3-phase
- *Maximum operating voltage: 620Vac, 3-phase
- Status output maximum conducting current: 40mA
- Status output maximum on resistance: 35 ohms @ 40mA
- Status output typical off resistance: >10 Mohm
- Status output maximum turn-on and turn-off delay: 850 milli-second

Status Output Interface Specifications:

- Rated Voltage: Recommended 5-35Vdc, 300Vac max.
- Rated Current: 40mA max.
- Wire Size: #28-14 AWG
- Torque: 2.25 lb. in.

Open Fuse Indicator Status Output Description:

The open fuse indicator status output acts very much like an on/off switch. With all three fuses in place and operating properly, this status output has a high resistance value of greater than ten mega-ohms. When one or more of the fuses are open, the status output becomes turned-on with a resistance value less than 35 ohms. This status output withstands voltage (AC or DC) up to 35 volts at off-state and conducts current up to 40 milli-amperes at on-state. Applying voltage and current exceeding these limits will result in damage to the components inside this status output device permanently. There is some time-delay when the status output changes on/off state. The open fuse communications or status output device includes optical isolators within the unit.

Communications output states:

Fuse Good	NO - High Resistance, >10 mega-ohms
Opened Fuse	NC - Low Resistance, < 35 ohms

Note: Operating this device beyond the above limits will cause permanent damage to the components on the board.

For applications requiring status output below a system voltage of 460V, contact Bussmann.

The examples shown below illustrate typical interface to Programmable Logic Controllers.

EXAMPLE 1: DIRECT INTERFACE TO PC/PLC

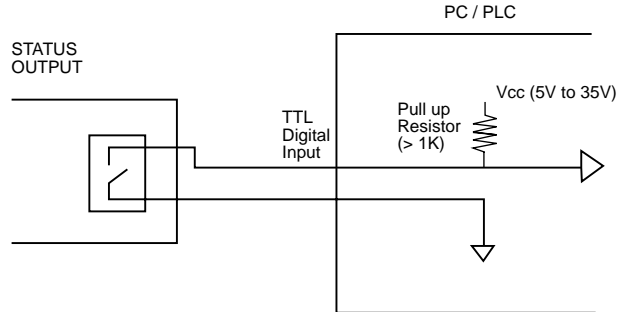

EXAMPLE 2: INTERFACE TO PC / PLC WITH OPTICAL ISOLATION

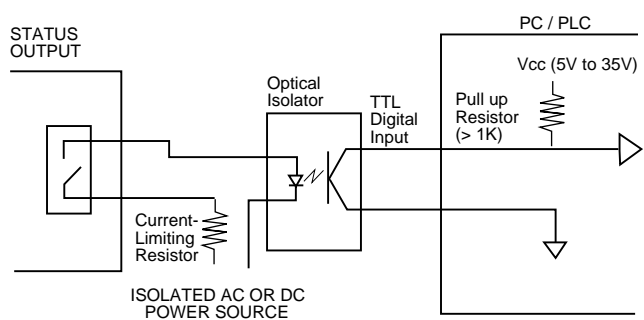

Note: When energized, a low load terminal voltage will be present when fuses are open or when pullout module is removed. The leakage current is limited to .5mA maximum.

Example of Output Voltage with three open fuses or pullout module removed.

Catalog Number Type of Indication	OPM-1038, OPM-1038R Standard	OPM-1038C, OPM-1038RC Communication
System Voltage (1L1-3L2-5L3)	Load Terminal Voltage (2T1-4T2-6T3)	
125Vdc *	12Vdc *	31Vdc *
480Vac, 3-phase	26Vac	56Vac
600Vac, 3-phase	33Vac	88Vac

*The communication device requires a minimum circuit voltage (1L1-3L2-5L3) of 460 volts for the status indicating device to operate. Below 460 volts, but above 120 volts the indicator lights will luminate, but there will not be any communication status output.

The only controlled copy of this Data Sheet is the electronic read-only version located on the Bussmann Network Drive. All other copies of this document are by definition uncontrolled. This bulletin is intended to clearly present comprehensive product data and provide technical information that will help the end user with design applications. Bussmann reserves the right, without notice, to change design or construction of any products and to discontinue or limit distribution of any products. Bussmann also reserves the right to change or update, without notice, any technical information contained in this bulletin. Once a product has been selected, it should be tested by the user in all possible applications.