

OA172S Series *

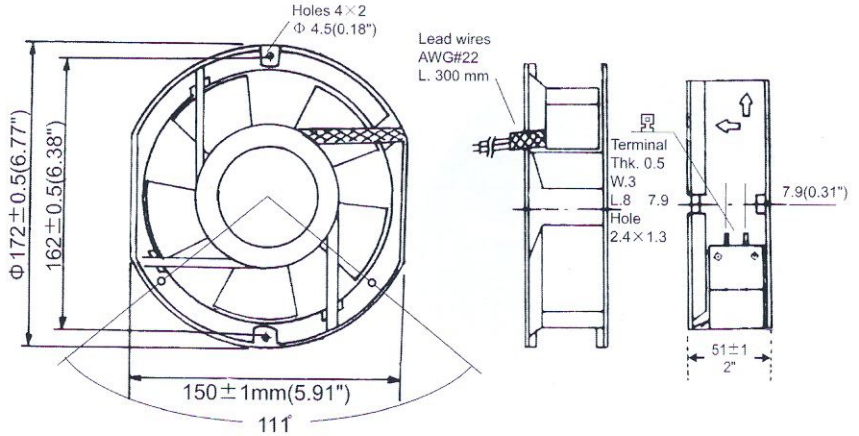

172 x 150 x 51mm
(6.7" x 5.9" x 2.0")



Frame	Diecast Aluminum	Operating Temperature Ball Bearing -40C ~ +70C Life Expectancy Ball Bearing 60,000 hours (L10 at 40C)
Impeller	PBT, UL94V-O plastic	
Connection	2x Lead Wires or Terminals	
Motor	Capacitor drive, impedance protected	
Bearing System	Dual ball	
Insulation Resistance	>100M ohm between lead-wire and frame (500VDC)	
Dielectric Strength	1 min at 1500 VAC, 50/60Hz	

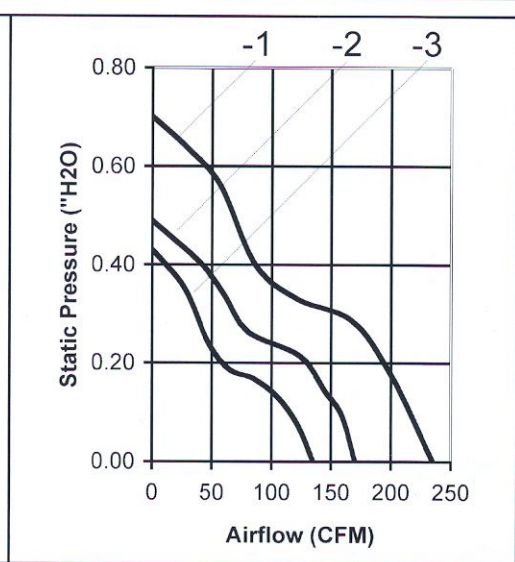

Model Number	Speed (RPM)	Airflow (CFM)	Noise (dB)	Volts AC	Voltage Range	Watts	Max. Static Pressure (\"H2O)
OA172SAP-11-()B	3200	235	52	115	80~130	35	0.70
OA172SAP-11-2()B	2400	170	42	115	80~130	20	0.49
OA172SAP-11-3()B	1800	135	33	115	80~130	16	0.43
OA172SAP-22-1()B	3200	235	52	230	160~260	35	0.70
OA172SAP-22-2()B	2400	170	42	230	160~260	20	0.49
OA172SAP-22-3()B	1800	135	33	230	160~260	16	0.43

() Indicate "T" for Terminal or "W" for Wire Leads



* Use prefix OA172AP instead of OA172SAP to specify round frame instead of the flat-sided, "stackable" version.