

OA180APL Series

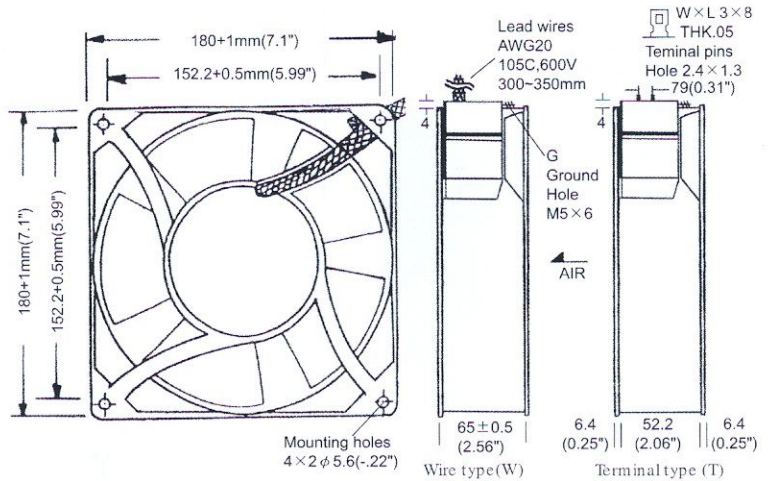

AC Fan - 115V, 230V
180 x 65mm (7.1" x 2.6")



Frame	Diecast Aluminum	<p><u>Operating Temperature</u> Ball Bearing -20C ~ +80C</p> <p><u>Life Expectancy</u> Ball Bearing 60,000 hours (L10 at 40C)</p> <p>Available as dual speed or dual voltage</p>
Impeller	PBT, UL94V-O plastic	
Connection	2x Lead Wires 20 AWG or terminals	
Motor	Single phase Capacitor induction, 2/4 pole, inner rotor, thermal protection	
Bearing System	Dual ball	
Insulation Resistance	>100M ohm between lead-wire and frame (500VDC)	
Dielectric Strength	1 min at 1500 VAC, 50/60Hz	

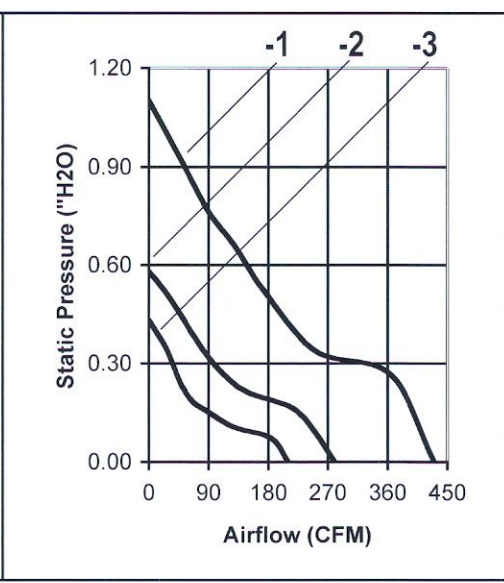

Model Number	Speed (RPM)	Airflow (CFM)	Noise (dB)	Volts AC	Voltage Range	Watts	Max. Static Pressure (H2O)
OA180APL-11-1 *	3300	430	60	115	60~130	70	1.10
OA180APL-11-2 *	2200	280	47	115	60~130	50	0.58
OA180APL-11-3 *	1650	210	40	115	60~130	38	0.43
OA180APL-22-1 *	3300	430	60	230	120~260	70	1.10
OA180APL-22-2 *	2200	280	47	230	120~260	50	0.58
OA180APL-22-3 *	1650	210	40	230	120~260	38	0.43

* Indicate "TB" for terminal or "WB" for wire leads