

## Rechargeable Sealed Lead-Acid Battery

# PS-12100

## 12 Volt 12.0 Amp. Hrs.



### Features:

- Absorbent Glass Mat (AGM) technology for superior performance.
- Valve regulated, spill proof construction allows safe operation in any position.
- Power/volume ratio yielding unrivaled energy density.
- Rugged plastic case and cover
- Approved for transport by air. D.O.T., I.A.T.A., F.A.A. and C.A.B. certified.
- U.L. recognized under file number MH 20845.



### PERFORMANCE SPECIFICATIONS

<b>Nominal Voltage</b> .....	12 volts (6 cells in series)
<b>Nominal Capacity</b>	
20 hour rate ( 600mA to 10.50 volts) .....	12.0 A.H.
10 hour rate ( 1150mA to 10.50 volts) .....	11.5 A.H.
5 hour rate ( 2000mA to 10.20 volts) .....	10.5 A.H.
1 hour rate (9000mA to 09.00 volts) .....	9.0 A.H.
<b>Approximate Weight</b> .....	8.8 pounds (4.0 kg)
<b>Energy Density (20 hour rate)</b> .....	1.64 Watt-hours/cubic inch (95.4 Watt-hours/l)
<b>Specific Energy (20 hour rate)</b> .....	16.4 Watt-hours/pound (36.0 Watt-hours/kg)
<b>Internal Resistance (Fully Charged Battery)</b> .....	18 milliohms (approximately)
<b>Maximum Discharge Current ( ≥ 7 Min.)</b> .....	36 amperes
<b>Maximum Short-Duration Discharge Current ( ≥ 10 Sec.)</b> .....	120 amperes
<b>Terminal configuration</b> .....	Quick disconnect tabs, "F1": 0.187" x 0.032" Mate with AMP. INC. FASTON "187" series For "F2" terminals use PS-12120
<b>Shelf Life — % of nominal capacity at 68° F (20° C)</b>	
1 Month.....	97%
3 Months.....	91%
6 Months.....	83%
<b>Operating Temperature Range</b>	
<b>Charge</b> .....	-4°F (-20°C) to 122°F (50°C)
<b>Discharge</b> .....	-4°F (-20°C) to 140°F (60°C)
<b>Case</b> .....	ABS Plastic

**Shelf Life and Storage**

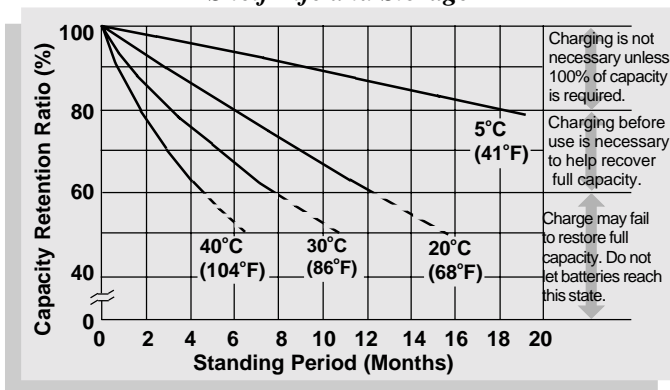

**Discharge Characteristics**

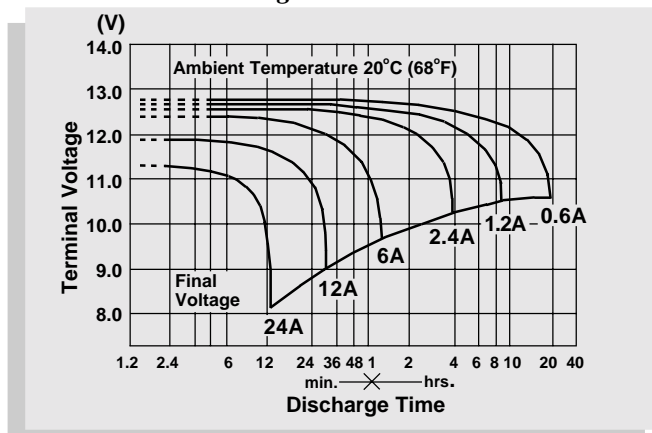

**Life Characteristics in Stand-By Use**

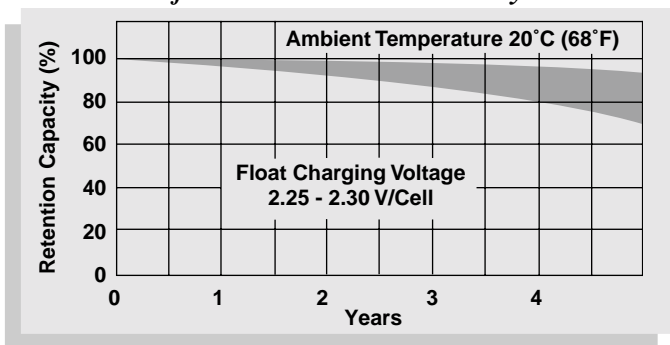

**Discharge Time vs. Discharge Current**

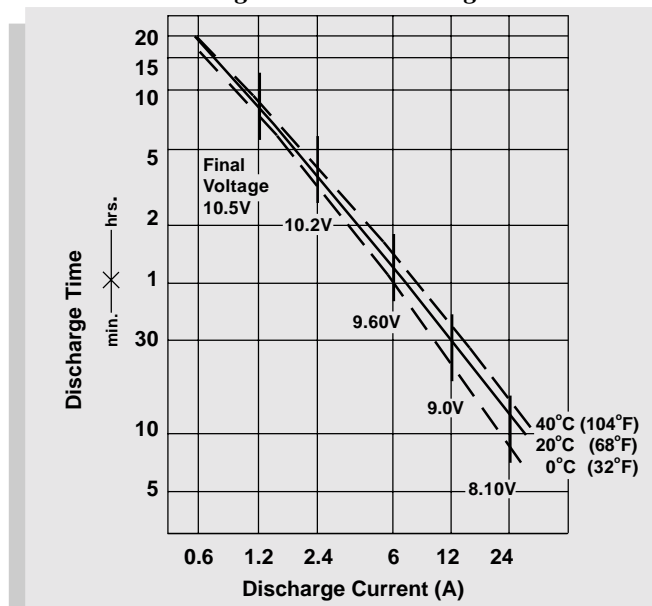

**Life Characteristics in Cyclic Use**

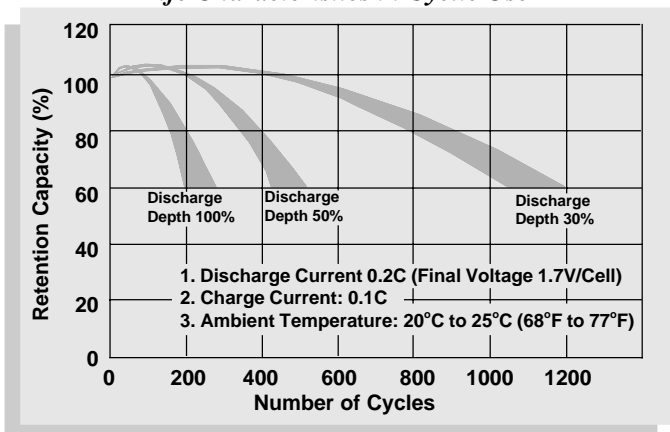

Physical Dimensions: in. (mm)

Terminals: F1 (mm)

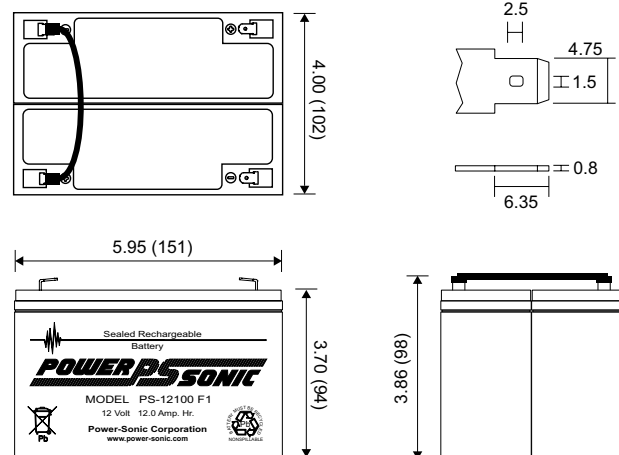

Tolerances are +/- 0.04 in. (+/- 1mm) and +/- 0.08 in. (+/- 2mm) for height dimensions. All data subject to change without notice.

**CHARGING**

**Cycle Applications:** Limit initial current to 3.6A. Charge until battery voltage (under charge) reaches 14.40 to 14.70 volts at 68°F (20°C). Hold at 14.40 to 14.70 volts until current drops to approximately 120mA. Battery is fully charged under these conditions, and charger should either be disconnected or switched to "float" voltage.

**"Float" or "Stand-By" Service:** Hold battery across constant voltage source of 13.50 to 13.80 volts continuously. When held at this voltage, the battery will seek its own current level and maintain itself in a fully charged condition.

**NOTE:** Due to the self-discharge characteristics of this type of battery, it is imperative that they be charged after 6-9 months of storage, otherwise permanent loss of capacity might occur as a result of sulfation.



**SALES & MARKETING**  
3106 Spring Street  
Redwood City, CA 94063 USA  
Tel: 650-364-5001 Fax: 650-366-3662  
national-sales@power-sonic.com



**ISO9001-2000**  
FM39170

www.power-sonic.com

**CUSTOMER SERVICE**  
7550 Panasonic Way  
San Diego, CA 92154 USA  
Tel: 619-661-2030 Fax: 619-661-3648  
customer-service@power-sonic.com