



## Rechargeable Sealed Lead-Acid Battery

# PS-12120L

## 12 Volt 12.0 Amp. Hrs.



### Features:

- Absorbent Glass Mat (AGM) technology for superior performance.
- Valve regulated, spill proof construction allows safe operation in any position.
- Power/volume ratio yielding unrivaled energy density.
- Rugged plastic case and cover
- Approved for transport by air. D.O.T., I.A.T.A., F.A.A. and C.A.B. certified.
- U.L. recognized under file number MH 20845



### PERFORMANCE SPECIFICATIONS

<b>Nominal Voltage</b> .....	12 volts (6 cells in series)
<b>Nominal Capacity</b>	
20 hour rate (600mA to 5.25 volts) .....	12.0 A.H.
10 hour rate (1.19A to 5.25 volts) .....	11.9 A.H.
5 hour rate (2.21A to 5.10 volts) .....	11.5 A.H.
1 hour rate (8.0A to 4.50 volts) .....	8.00 A.H.
15 min rate (25.5A to 4.50 volts) .....	6.40 A.H.
<b>Approximate Weight</b> .....	9.9 pounds (4.5 kg)
<b>Energy Density (20 hour rate)</b> .....	1.14 Watt-hours/cubic inch (69.0 Watt-hours/l)
<b>Specific Energy (20 hour rate)</b> .....	13.1 Watt-hours/pound (28.8 Watt-hours/kg)
<b>Internal Resistance (Fully Charged Battery)</b> .....	25 milliohms (approximately)
<b>Maximum Discharge Current ( ≤ 7 Min.)</b> .....	36 amperes
<b>Maximum Short-Duration Discharge Current ( ≤ 10 Sec.)</b> .....	120 amperes
<b>Terminal configurations</b> .....	Polarized quick disconnect tabs, Positive: 0.250" x 0.032" Negative: 0.187" x 0.032". Mate with AMP. INC FASTON "250/187" series
<b>Shelf Life — % of nominal capacity at 68° F (20° C)</b>	
1 Month.....	97%
3 Months.....	91%
6 Months.....	83%
<b>Operating Temperature Range</b>	
<b>Charge</b> .....	-4°F (-20°C) to 122°F (50°C)
<b>Discharge</b> .....	-4°F (-20°C) to 140°F (60°C)
<b>Case</b> .....	ABS Plastic

**Shelf Life and Storage**

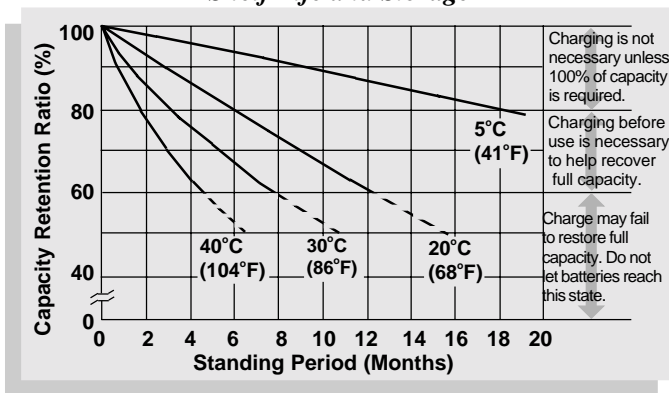

**Discharge Characteristics**

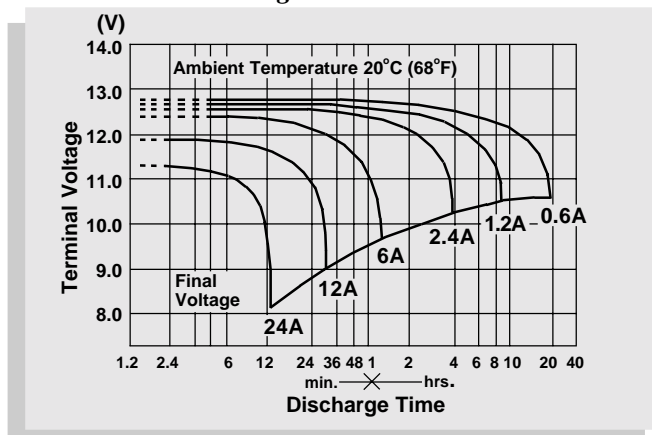

**Life Characteristics in Stand-By Use**

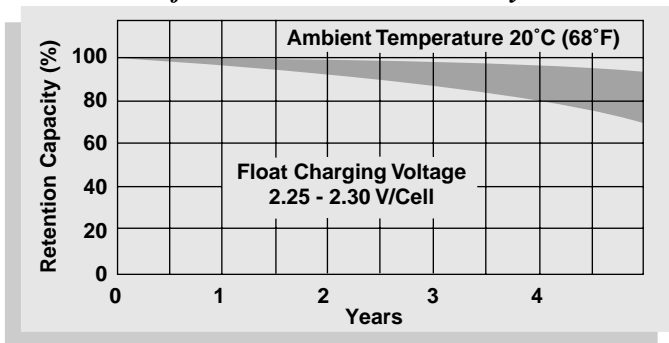

**Discharge Time vs. Discharge Current**

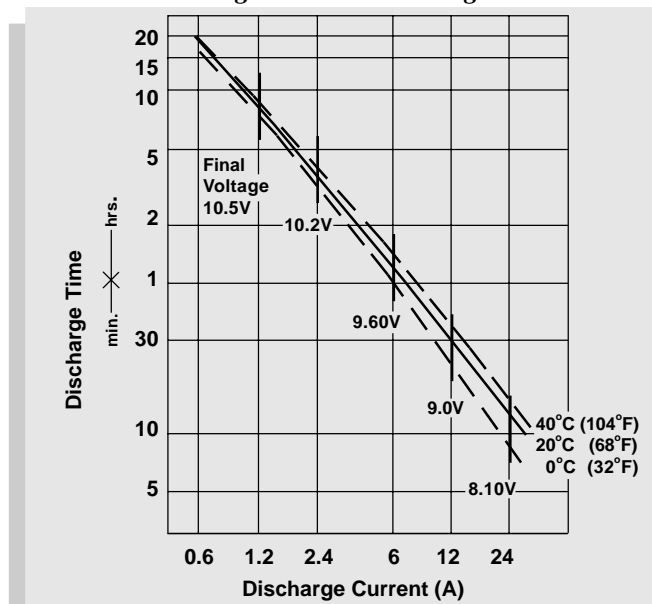

**Life Characteristics in Cyclic Use**

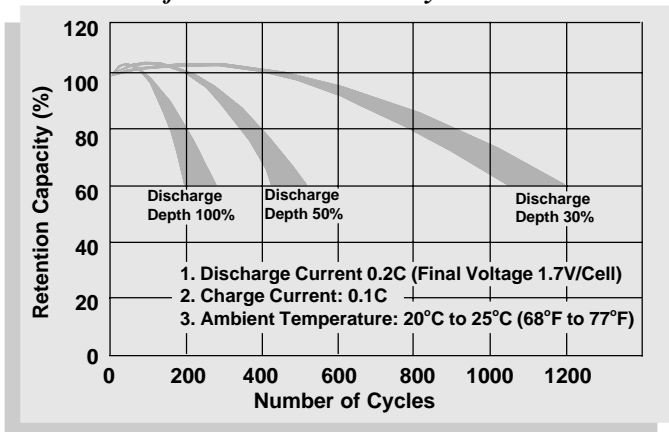

Physical Dimensions: in. (mm)

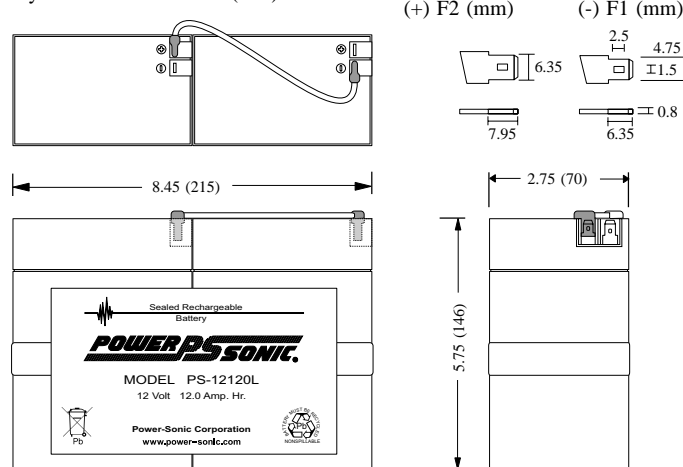

Tolerances are +/- 0.04 in. (+/- 1mm) and +/- 0.08 in. (+/- 2mm) for height dimensions. All data subject to change without notice.

**CHARGING**

**Cycle Applications:** Limit initial current to 2.4A. Charge until battery voltage (under charge) reaches 14.40 to 14.70 volts at 68°F (20°C). Hold at 14.40 to 14.70 volts until current drops to approximately 120mA. Battery is fully charged under these conditions, and charger should either be disconnected or switched to "float" voltage.

**"Float" or "Stand-By" Service:** Hold battery across constant voltage source of 13.50 to 13.80 volts continuously. When held at this voltage, the battery will seek its own current level and maintain itself in a fully charged condition.

**NOTE:** Due to the self-discharge characteristics of this type of battery, it is imperative that they be charged after 6-9 months of storage, otherwise permanent loss of capacity might occur as a result of sulfation.



**CORPORATE OFFICE**  
7550 Panasonic Way  
San Diego, CA 92154 USA  
Tel: +1-619-661-2020  
Fax: +1-619-661-3650  
national-sales@power-sonic.com

**CUSTOMER SERVICE**  
Tel: +1-619-661-2030  
Fax: +1-619-661-3648  
customer-service@power-sonic.com

**SALES / INTERNATIONAL**  
Tel: +1-650-364-5001  
Fax: +1-650-366-3662  
battery@power-sonic.com

www.power-sonic.com